



Professional *Ultra*™ Hybrid Electric with LeakGuard™ is the most efficient water heater available

Efficiency

- Up to 4.0 UEF reduces operating cost
- ENERGY STAR® rated

Performance

- Delivers hot water faster than most standard electric water heaters
- Ambient operating range: 37-145° F is widest in class, offering more days of HP operation annually; designed to meet Northern Climate Spec (Tier 4)

Easy Installation

- Easy access side connections
- Quick access to electrical junction box
- Easily replaces a standard electric water heater

Integration

- LED Screen with built-in water sensor alert with audible alarm¹
- Integrated EcoNet® WiFi-connected² technology and free mobile app gives users control over water heater, allowing for customizable temperature, vacation settings, energy savings and system monitoring at home or away. Visit Ruud.com/hybridsolutions



- Integrated leak detection and prevention system with factory installed auto water shut-off valve limits leaks to no more than 20 ounces of water^{1, 3}
- LeakSense™ Built-in Leak Detection System detects any leak large or small, internal or external^{1, 4}

Operation Modes

- Energy Saver
- Heat Pump
- High Demand
- Electric
- Vacation/Away: 2-28 days (or placed on hold indefinitely)

Plus...

- Premium grade anode rod with resistor extends the life of the tank
- 3/4" NPT water inlet and outlet; 3/4" condensate drain connections
- Incoloy stainless steel resistor elements
- Dry-fire protection
- Easy access, top mounted washable air filter
- 2" Non-CFC foam insulation
- Enhanced flow brass drain valve
- Temperature and pressure relief valve installed
- Design certified to NSF/ANSI 372 (Lead Content)

Warranty

- 10-Year limited tank and parts warranty
See Residential Warranty Certificate for complete information

Units meet or exceed ANSI requirements and have been tested according to D.O.E. procedures. Units meet or exceed the energy efficiency requirements of NAECA, ASHRAE standard 90, ICC Code and all state energy efficiency performance criteria.



Professional *Ultra* Hybrid

40, 50, 65 and 80-Gallon Capacities
208-240 Volt / 1 PH Electric



LEED Points = 3

¹Available with select models. ²WiFi broadband internet connection required. ³Source: Ruud Leak-Sensing Data; testing under a vacuum lock using 50-gallon tank, no expansion tank, average tank pressure of 40 psi, assuming no additional faucets are opened. ⁴Water leaks from the heater only, as tested across scenarios including a minimum of 5.5mL/hr volume leak rate, using most common installation scenarios.

See specifications chart on next page.

Professional *Ultra*™ Hybrid Specifications

DESCRIPTION					ENERGY INFO		FEATURES							SHIPPING WEIGHTS	
NOMINAL GALLON CAPACITY	RATED GALLON CAPACITY	MODEL NUMBER	MODEL VARIANT	ELECTRIC BREAKER SIZE	UNIFORM ENERGY FACTOR (UEF)	EST. YEARLY ENERGY COST	COMPRESSOR BTU/H	SOUND LEVEL (dBA)	UEF FIRST HR. RATING G.P.H.	RECOVERY IN G.P.H 90° F RISE	ELEMENT WATTAGE	TOTAL UNIT WATTAGE	MAX AMPS	UNIT WT. (LBS.)	APPROX. SHIP WT. (LBS.)
30 Amp with LeakGuard															
40	36	PROUH40 T2 RU375-SO	700656	30	3.75	\$104	4,200	49	60	26	4,500	5,000	21	157	174
50	45	PROUH50 T2 RU375-SO	700647	30	3.75	\$104	4,200	49	67	27	4,500	5,000	21	178	218
65	59	PROUH65 T2 RU375-SO	700648	30	3.85	\$155	4,200	49	75	27	4,500	5,000	21	225	262
80	72	PROUH80 T2 RU375-SO	700655	30	4.00	\$149	4,200	49	87	27	4,500	5,000	21	244	281
30 Amp without LeakGuard															
40	36	PROUH40 T2 RU375-30	700493	30	3.75	\$104	4,200	49	60	27	4,500	5,000	21	157	174
50	45	PROUH50 T2 RU375-30	700471	30	3.75	\$104	4,200	49	67	27	4,500	5,000	21	178	218
65	59	PROUH65 T2 RU375-30	700472	30	3.85	\$155	4,200	49	75	27	4,500	5,000	21	225	262
80	72	PROUH80 T2 RU375-30	700492	30	4.00	\$149	4,200	49	87	27	4,500	5,000	21	244	281
15 Amp without LeakGuard															
40	36	PROUH40 T2 RU375-15	700487	15	3.45	\$78	4,200	49	46	16	2,250	2,750	12	157	174
50	45	PROUH50 T2 RU375-15	700479	15	3.75	\$104	4,200	49	52	16	2,250	2,750	12	178	218
65	59	PROUH65 T2 RU375-15	700485	15	3.55	\$110	4,200	49	54	16	2,250	2,750	12	225	262
80	72	PROUH80 T2 RU375-15	700486	15	3.70	\$105	4,200	49	67	16	2,250	2,750	12	244	281

Estimated energy cost based on a national average electricity cost of \$0.12 /kWh. Uniform Energy Factor and rated gallon capacity based on Department of Energy (DOE) requirements. All units have integrated WiFi control board.

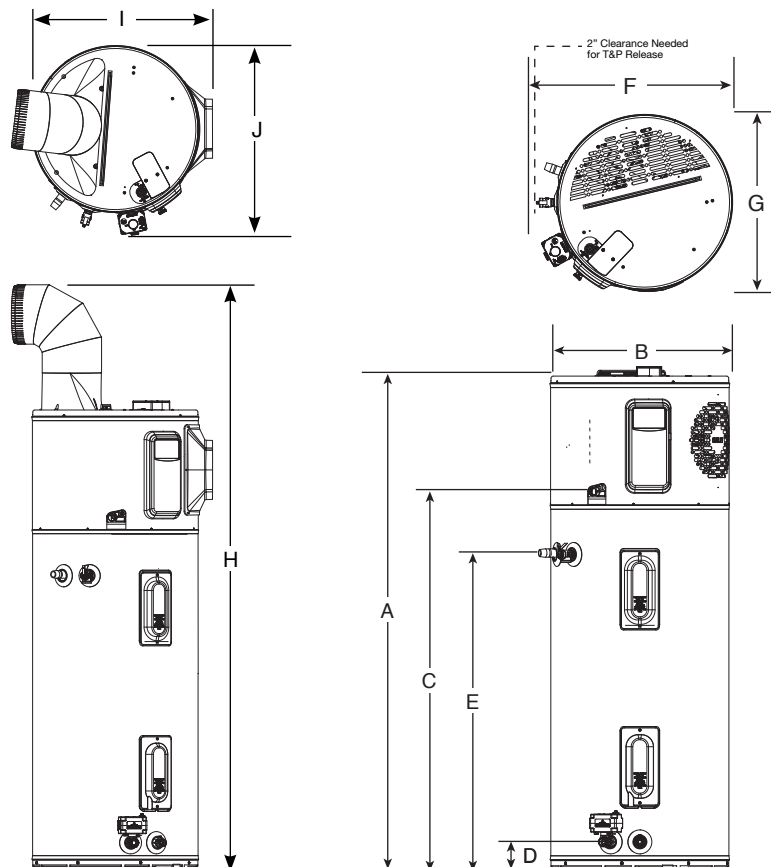

DESCRIPTION		DIMENSIONS (SHOWN IN INCHES)									
NOMINAL GALLON CAPACITY	MODEL NUMBER	A	B	C	D	E	F	G	H	I	J
40	PROUH40	62-5/16	20-1/4	47	3-5/8	39-5/8	23-3/8	20-1/2	78-7/8	22-3/8	23-1/4
50	PROUH50	61-3/4	22-1/4	47	3-5/8	39-5/8	25-3/8	22-1/2	78-5/8	24-3/8	25-9/16
65	PROUH65	64-3/16	24-1/4	49	3-7/8	42-3/8	27-1/2	24-5/8	81-1/8	26-1/2	27-3/8
80	PROUH80	74-3/16	24-1/4	59	3-7/8	42-3/8	27-1/2	24-5/8	91	26-1/2	27-3/8

Hybrid Water Heater Installation Guidelines to Provide Optimal Efficiency

Heater: Not Ducted

Room size: Larger than 700 ft³ (e.g. 7' x 10' x 10').
 Requirements: No additional ventilation needed.

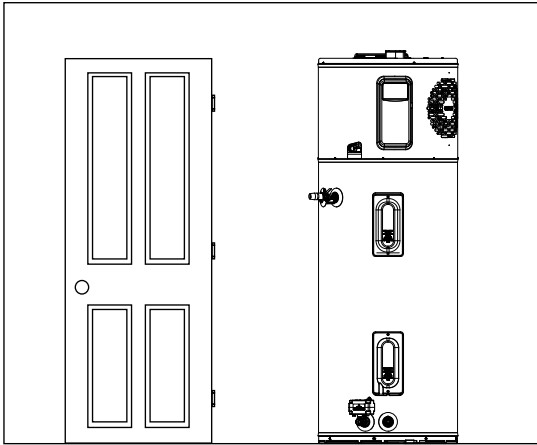

Heater: Not Ducted

Room size: Smaller than 700 ft³ (e.g. 7' x 10' x 10').
 Requirements: Full louvered door OR two louvers top and bottom. See below.

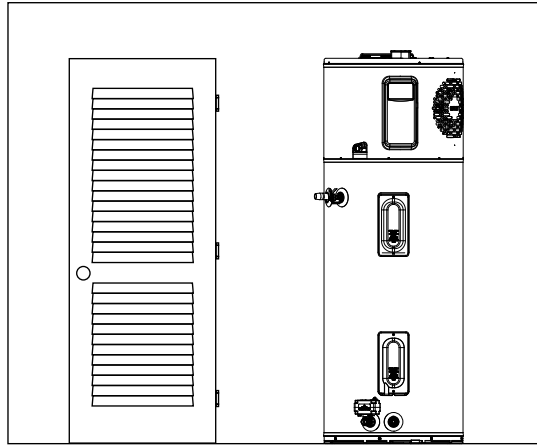

Heater: Not ducted

Room: Small Closet

- Requirements:
- * Air gap under door equal to 18 in² (0.75" clearance).
 - * Louver must be located the same height on door as the air exhaust on heater.
 - * Heater air exhaust must be positioned towards louver within one foot of door.

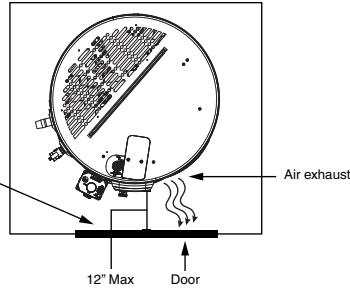
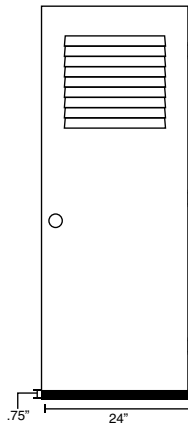

Heater: Ducted with inlet OR outlet duct

Room size: Any size room
 Requirements: Air gap under door equal to 18 in² (0.75" clearance)

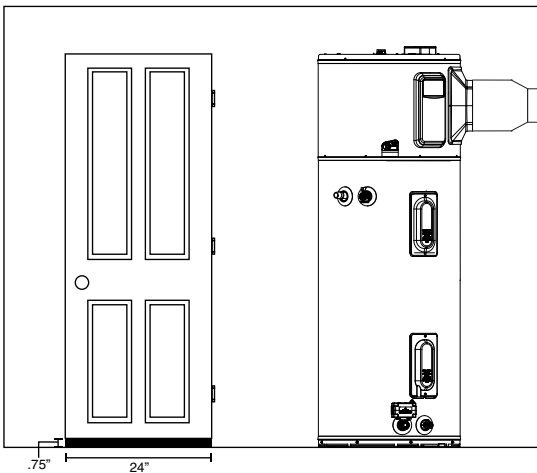

Heater: Ducted with inlet AND outlet duct

Room size: Any size room
 Requirements: No additional ventilation needed.

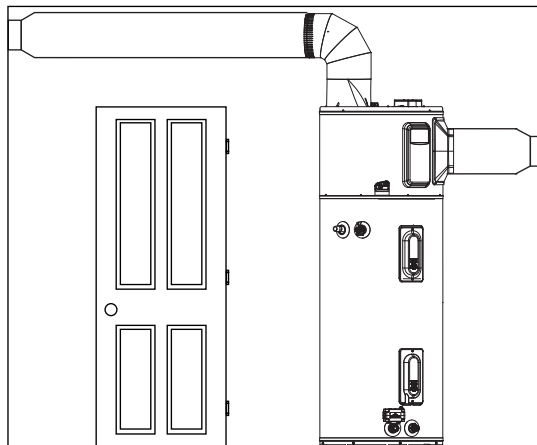



Hybrid Accessories List

DESCRIPTION	USE FOR
Leak Sensor	Automatic detection of internal and external leaks
Shutoff Valve	Automatic shut off of water supply to unit
Inlet Duct Adapter	Allows for ducting to be connected on the top inlet
Outlet Duct Adapter	Allows for ducting to be connected to the unit
Earthquake Isolation Kit	Installations in seismic regions
Vibration Isolation Kit	Installation on non-concrete floors
8" Diameter UL Certified Termination Kit	Termination to the outside or to the attic with 8" diameter
7" Diameter UL Certified Termination Kit	Termination to the outside or to the attic with 7" diameter
6" Diameter UL Certified Termination Kit	Termination to the outside or to the attic with 6" diameter
5" Diameter UL Certified Termination Kit	Termination to the outside or to the attic with 5" diameter
8" Ruud Approved Damper Kit	Exhaust only to the outside ducting configuration (no inlet duct)
25' Flexible 8" Diameter Duct Kit	For up to 25' of ducting
Rigid Elbow Duct Kit	Installation in tight places where space needs to be minimized
UPGRADE KIT	
Leak Sensor & Shutoff Valve Kit	Upgrade 15 and 30 Amp models to protect your customers home from water damage with leak detection and auto shutoff valve

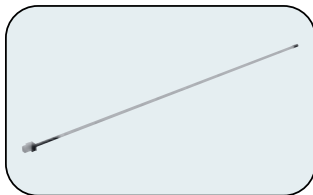

Leak Sensor



Shutoff Valve



Inlet Duct Adapter



Outlet Duct Adapter



Earthquake Isolation Kit



Vibration Isolation Kit

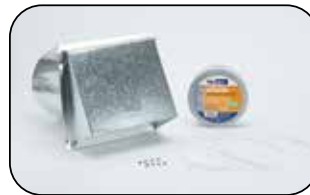

8" Diameter UL Certified Termination Kit



7" Diameter UL Certified Termination Kit



6" Diameter UL Certified Termination Kit



5" Diameter UL Certified Termination Kit



8" Ruud Approved Damper Kit



25' Flexible 8" Diameter Duct Kit



Rigid Elbow Duct Kit

UPGRADE KIT (for models without LeakGuard only) – Add leak detector and shutoff valve to protect from water damage

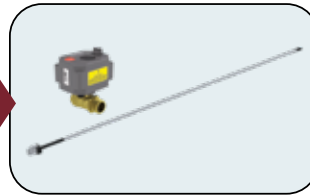

Leak Sensor & Shutoff Valve Kit

In keeping with its policy of continuous progress and product improvement, Ruud reserves the right to make changes without notice.